

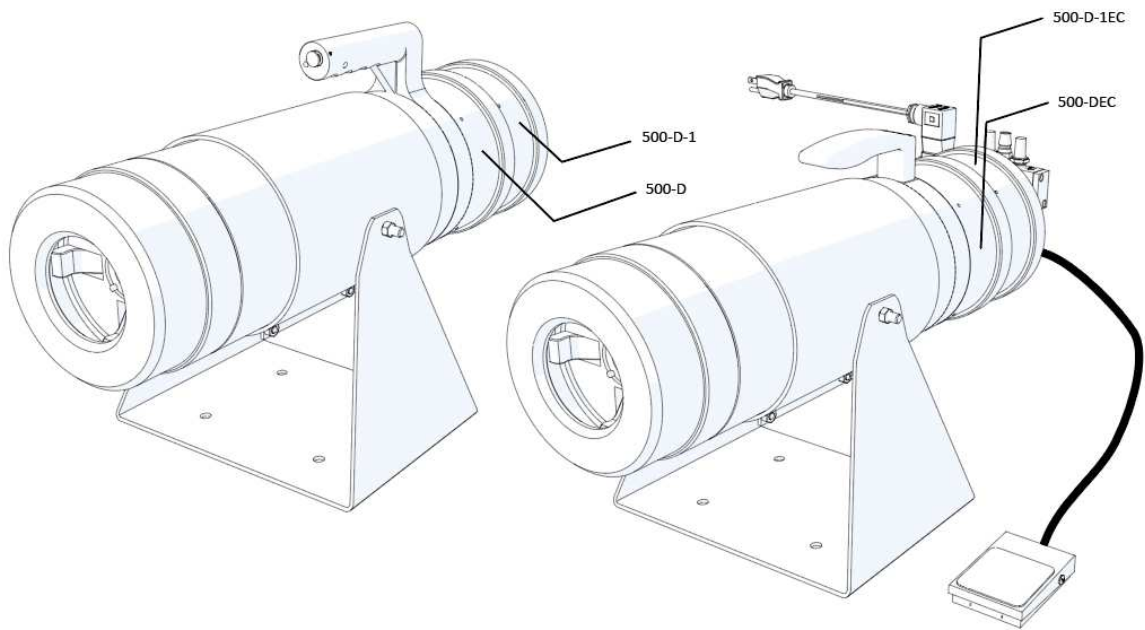

500 Series Customer Manual



Models: 500-D, 500-DEC, 500-D-1, 500-D-1EC

Sales Office:
411 Hackensack Ave., Ste#200
Hackensack, NJ 07601
Email: sales@rennsteig.us
Phone: 330-315-3044

Production Plant / Warehouse, CA
4040 Adolfo Rd.
Camarillo, CA 93012
Email: warehouse@rennsteig.us

Warehouse, NJ
403 Kennedy Blvd.
Somerdale, NJ 08083
Email: info@rennsteig.us

Principals:
Sascha Zmiskol
(President)
Mirko Reffke
(Vice President)
DUNS 941290558
Tax ID 20-423 3171



Dear Valued Customer,

Thank you for choosing Rennteig Tools for your recent purchase. We greatly appreciate your trust in our products.

This is what drives our success.

At Rennteig Tools, we strive to deliver high-quality tools that meet your needs and exceed your expectations. Our top-of-the-line tools are designed for maximum performance, ease of use and long-lasting durability for more than 60 years.

We are confident that your purchase will serve you well.





Our dedicated support team is ready to provide the guidance you need. We value your satisfaction and are committed to ensuring your success with our products.

We are honored to be your trusted partner and we look forward to serving you in the future.

Best regards,
The Rennteig Tools Team

Models

The different available models are shown in the table below.

P/N	Description	Capacity (AWG)			Activation Type
		Contacts Solid Contacts	Insulated Terminals	Non-Insulated Terminals	
P-500-D	Pneumatic Crimping Machine	20 - 4/0	22 - 3/0	26 - 4/0	
P-500-DEC	Pneumatic Crimping Machine with EC-Unit	20 - 4/0	22 - 3/0	26 - 4/0	
P-500-D-1	Pneumatic Crimping Machine	20 - 4/0	22 - 4/0	22 - 250 MCM	
P-500-D-1EC	Pneumatic Crimping Machine with EC-Unit	20 - 4/0	22 - 4/0	22 - 250 MCM	



Hand Trigger

Those machines are operated with a trigger at the tip of the handle.



Foot Switch

Those machines are operated with a foot switch, which can be placed freely.



Contents

1. Safety Instructions	4
2. Setup Overview.....	5
2.1 Setup.....	5
2.2 Connecting Air (EC-Unit)	6
2.2.1 EC-Unit Components	7
2.3 Connecting Air (Hand Trigger)	8
2.4 Connecting Air (Foot Pedal P/N 104)	9
2.5 Installing The Locator	10
2.6 Installing The Die Assembly.....	11
2.7 Installing The Cover Nut	12
3. Calibration	13
3.1 Calibrating The Die Set	13
3.2 Changing The Indentors	14
3.3 Perform Calibration.....	15
3.4 Calibrating The Tool.....	17
4. General Maintenance	18
5. General Overhaul.....	18
6. Exploded View 500-D	19
7. Exploded View 500-D-1.....	20
8. Exploded View 500-DEC.....	21
9. Exploded View 500-D-1EC.....	22
10.Exploded View Toggle Assembly 500-10T.....	23
11.Cycling Valve Assembly	24
11.1 Changing The Cycling Valve (P/N 500-33)	24
12.Customer Service	25
13.Warranties And Claims.....	26
14.Notes	27
15.Also Available from Rennsteig Tools.....	28



1. Safety Instructions



DANGER

Indicates an immediate hazard that may result in moderate or severe injury.



CAUTION

Indicates a condition that may result in damage to the product or equipment.



SAFETY GLASSES

Always wear approved eye protection while operating equipment.



EAR PROTECTION

Always wear appropriate ear protection while operating equipment.



HIGH AIR PRESSURE

Always disconnect the air when not in use or when cover nut or tool holder is detached.



DANGER – MOVING PARTS

Moving parts can crush and cut. Always keep guards in place during normal operation.



Failure to observe this warning could result in severe injury or death.



DANGER – ELECTRIC SHOCK HAZARD

This tool is not insulated. When using this unit near energized electrical lines, use proper personal protective equipment.



Failure to observe this warning could result in severe injury or death.



DANGER – FIRE HAZARD

Do not use solvents or flammable liquids to clean the crimping tool. They could ignite and cause serious injury or property damage.



Failure to observe this warning could result in burns or severe injury.



DANGER – SKIN INJECTION HAZARD

Do not use your hands to check for oil leaks. Highly pressurized oil punctures the skin, causing serious injury, gangrene or death.



If injured, seek immediate medical help to remove the oil.



DANGER

Inspect the tool and die assemblies before each use.

Replace any worn or damaged parts. A damaged or improperly assembled tool can break and strike nearby personnel.

Failure to observe this warning could result in severe injury or death.



CAUTION

Do not place the tool in a vise. The crimping tool is designed for hand-held operation.

Protect the crimping tool from rain and moisture. Water damages the crimping tool and the EC-Unit. Failure to observe these precautions can result in injury or property damage.



CAUTION

Do not perform any service or maintenance other than those described in this manual.

Never alter, modify, or misuse the equipment. Failure to observe this advice can result in injury or property damage.



2. Setup Overview

Each tool is shipped from the factory pre-assembled. However, the tool will not have a locator and die assembly pre-installed. These are purchased separately and must be installed by the user.

The tool can be operated manually through the hand trigger, or through a foot pedal (P/N 104). If you bought a machine with EC unit (500-DEC, 500-D-1EC), the foot switch is already included.

An air supply of 90-115 PSI is required.

In North America, an electrical supply of 110/120 volts AC is required.

In Europe (220/240 volt AC), you will need a voltage converter to operate the tool.

It is mandatory for the converter to meet the following requirements:

- Input voltage of 220 / 230 / 240 Vac
- Power capacity of 100 watts or greater
- Universal socket for the machine's power cord
- UL / CSA / VDE approved, CE certified
- EMI standards per EMC directive 2014/30/EU

The voltage converter is plugged into the local 220/240V receptacle, with the tool 110/120V power cord plugged into the voltage converter.

2.1 Setup

1. Install the locator.
2. Install the die.
3. Install the cover nut.
4. Connect the air supply to the tool.
5. Check tool operation – cycle tool with air, without inserting a wire and contact to check operation of indentors.
6. Gage Tool.
7. Proceed with normal operation.



2.2 Connecting Air (EC-Unit)

Every EC-Model of our machines includes an EC-Unit. The EC-Unit is pre-assembled, but not attached to the machine when delivered to prevent damage. Attach the EC-Unit with the 90° Elbow (7) to the rear end of the machine as shown in the picture below. The air inlet (2) is tapped to accommodate 1/4" NPT fittings. The air fitting is not supplied, because it is not possible to anticipate which one is used due to the large variety of available fittings. A direct pipe threaded fitting or quick disconnect can be used. When installing check for leakage or damaged threads to prevent pressure loss.

i If you have upgraded your machine to EC, seal the 1/4" NPT threaded hole in the rear of the handle.

- 1 Foot Switch (pre-assembled)
- 2 Air inlet
- 3 Power cord (110V)
- 4 Solenoid Timer
- 5 Valve
- 6 Muffler
- 7 Elbow

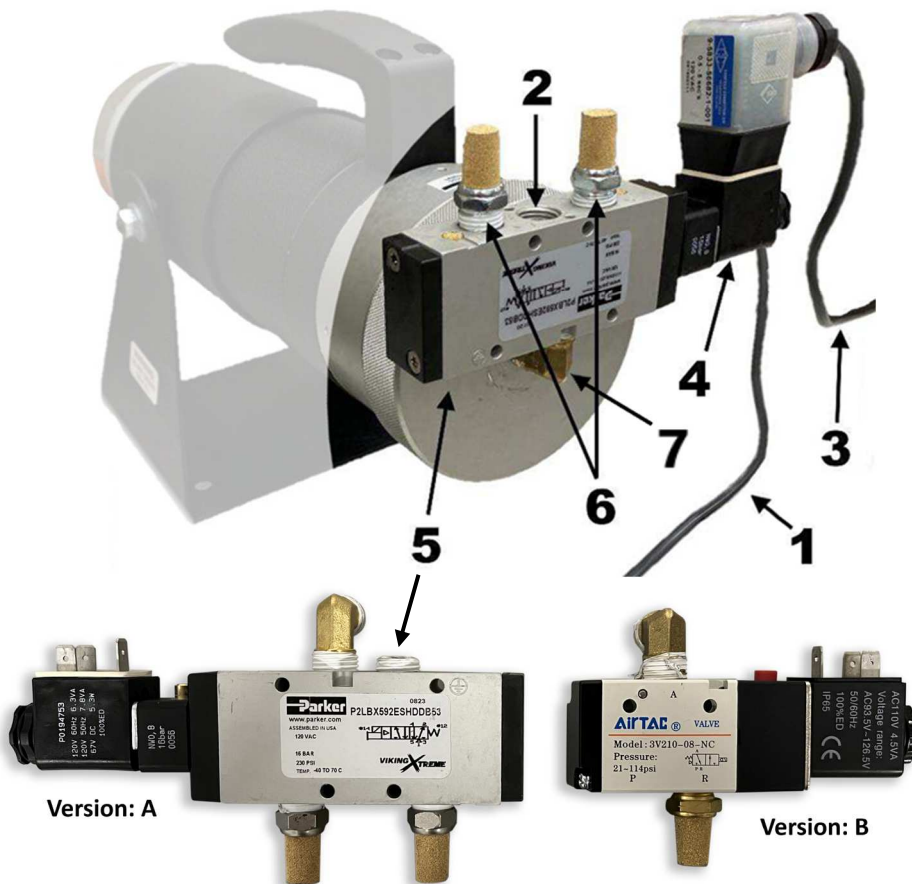



2.2.1 EC-Unit Components

P-EC-6

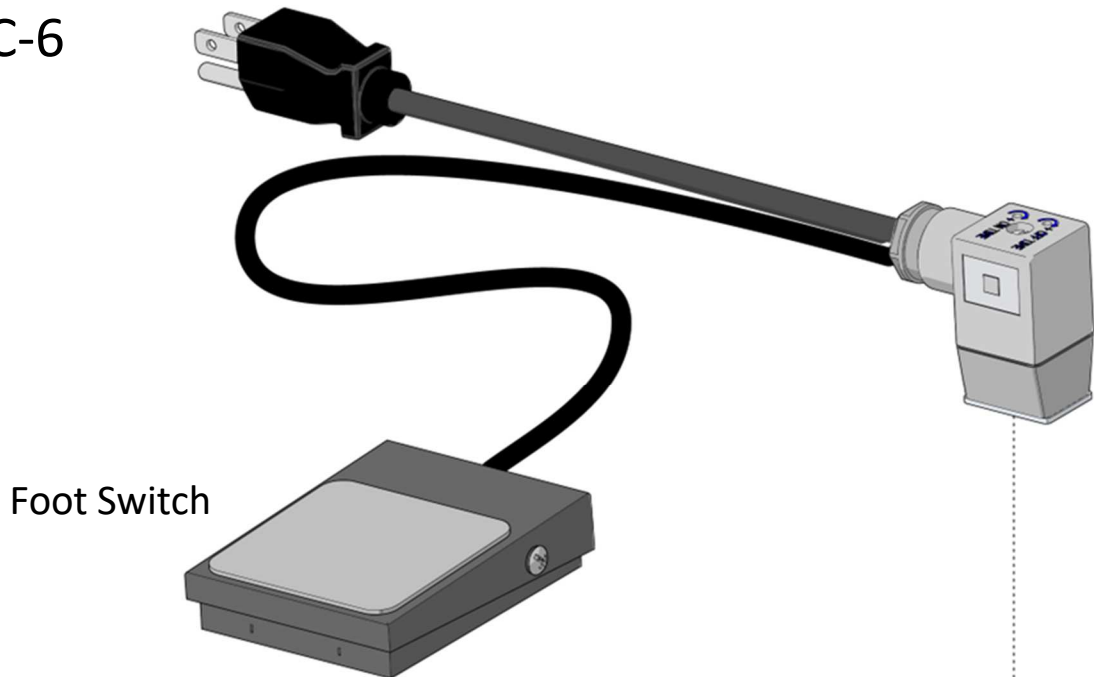

Foot Switch

P-EC-9

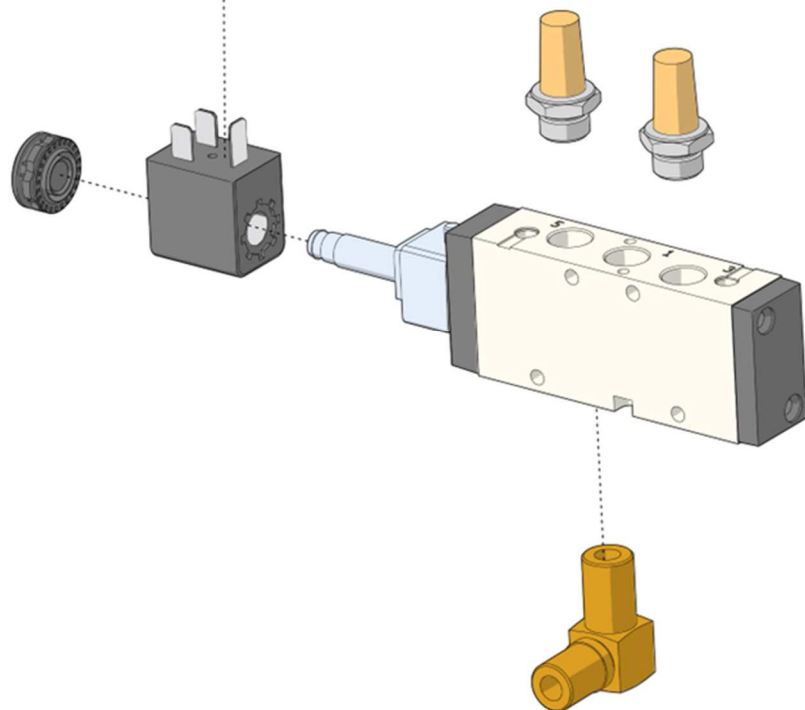



2.3 Connecting Air (Hand Trigger)

The air inlet port on the rear of the handle is tapped to accommodate 1/4" NPT fittings. Connect the air supply to the port at the rear of the handle and ensure that the connection is tight enough to prevent leaks.

We recommend a 1/4" air hose (inside diameter) to be used.

i Keep the 1/4" hole in the center of the rear cover sealed with a pipe plug when operating the tool with the hand trigger.

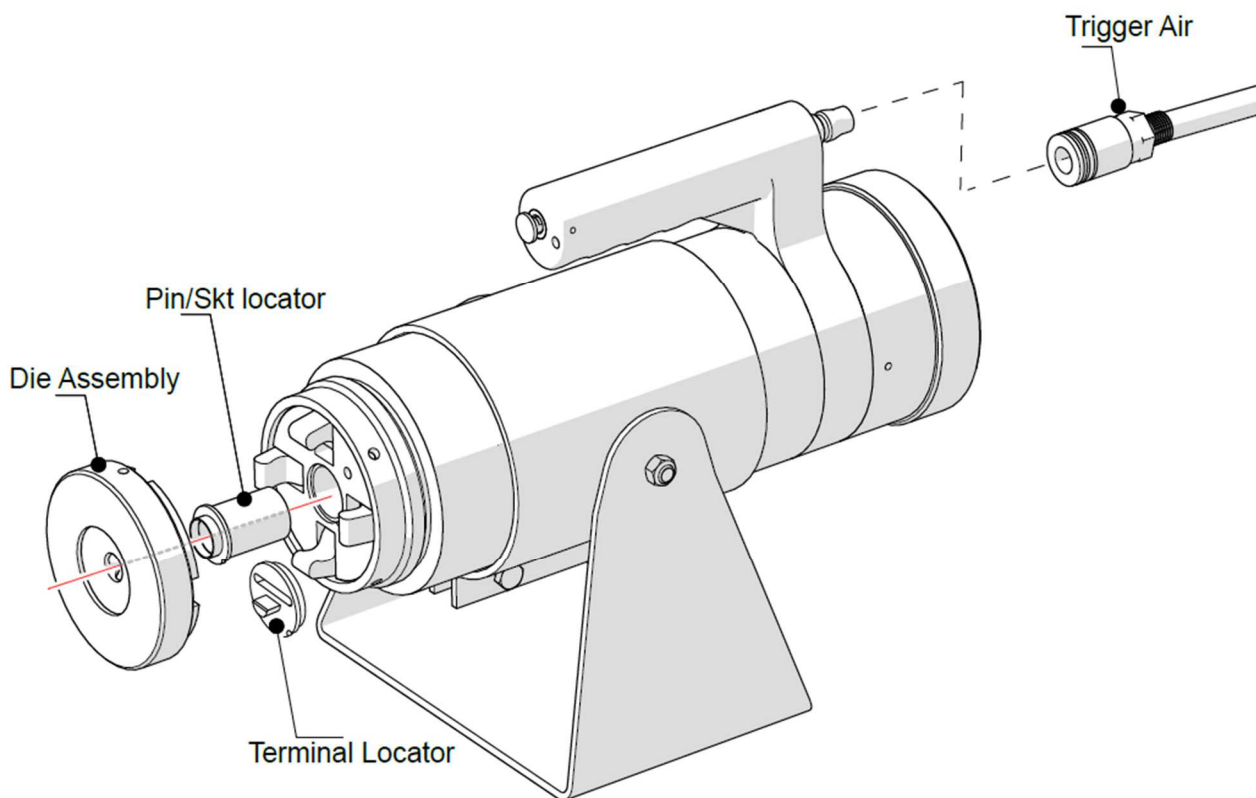



2.4 Connecting Air (Foot Pedal P/N 104)

Connect the air hose to the port in the center of the rear cover. The air hose connected to the rear cover must be connected to the outlet port of the foot pedal. Connect the hose from the air supply to the inlet port of the foot pedal.

i Keep the 1/4" hole in the rear of the handle sealed with a pipe plug when operating the tool with the foot switch.

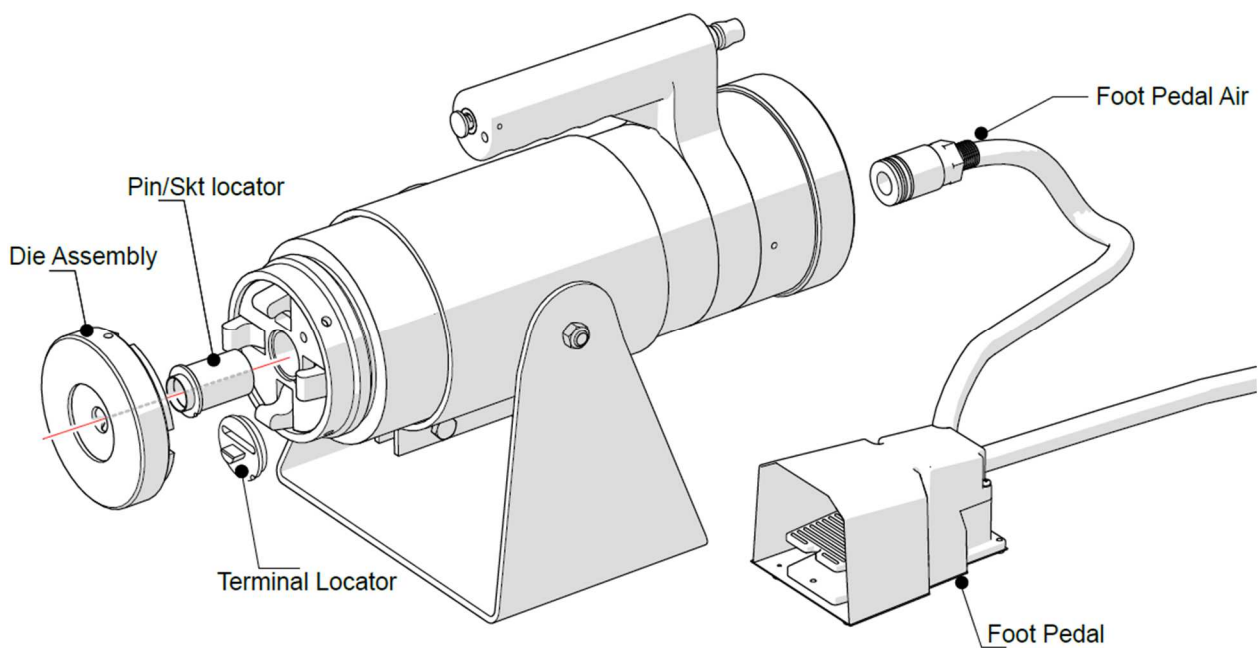



2.5 Installing The Locator

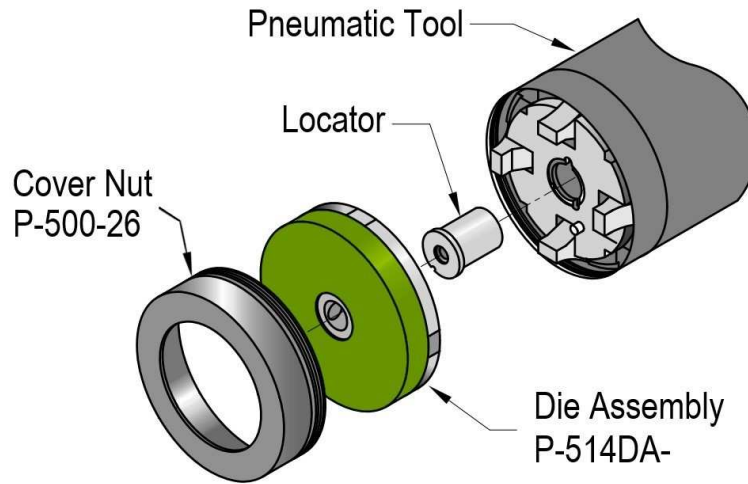

1. Disconnect the air supply from the tool.
2. Remove the cover nut and die assembly if necessary.
3. Insert the locator into the retainer.
4. It is mandatory that the notch on the locator lines up with the orientation pin in the retainer.
5. When properly installed, the locator is flush with the retainer and the locator part number is visible.

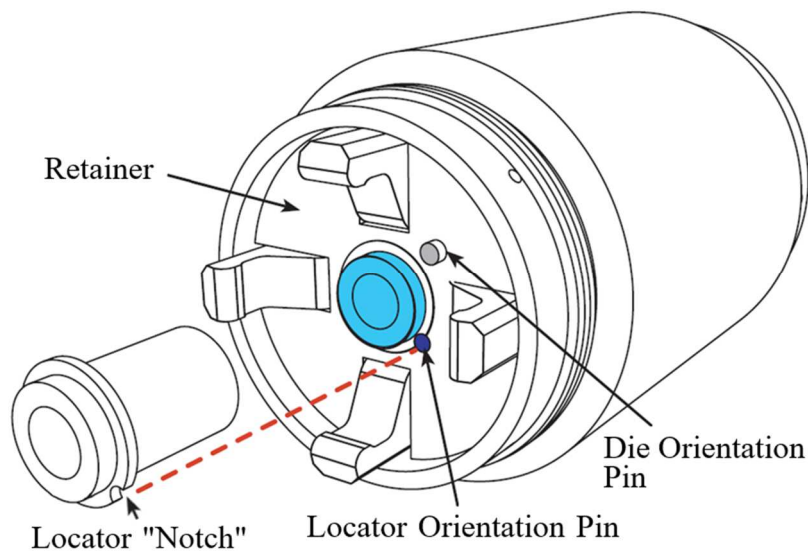

Never crimp without a locator in the tool. Contacts can fall into the tool causing the tool to jam and possibly damaging the unit.





2.6 Installing The Die Assembly

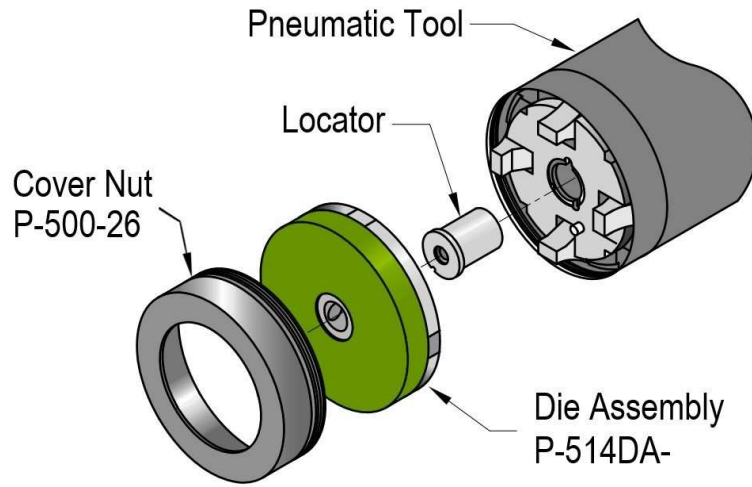

1. Disconnect the air supply from the tool.
2. Find the orientation Pin in the retainer, and the pin hole in the rear of the die assembly.
3. Orient this hole to fit over the index pin in the retainer and press the die assembly in place. The die assembly must sit flat on the retainer.

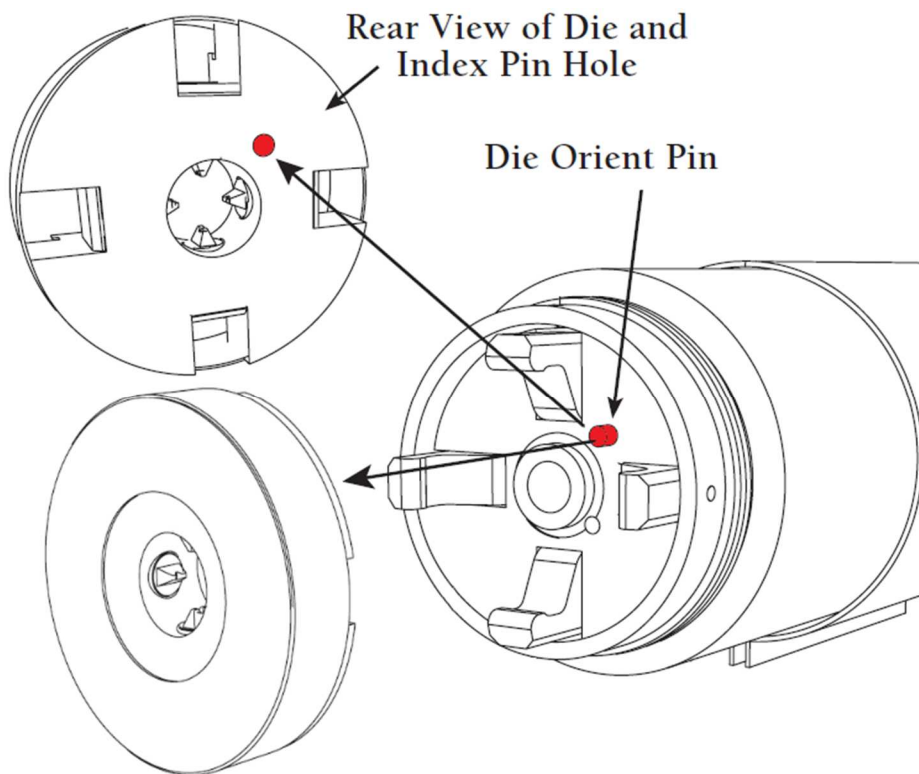



2.7 Installing The Cover Nut

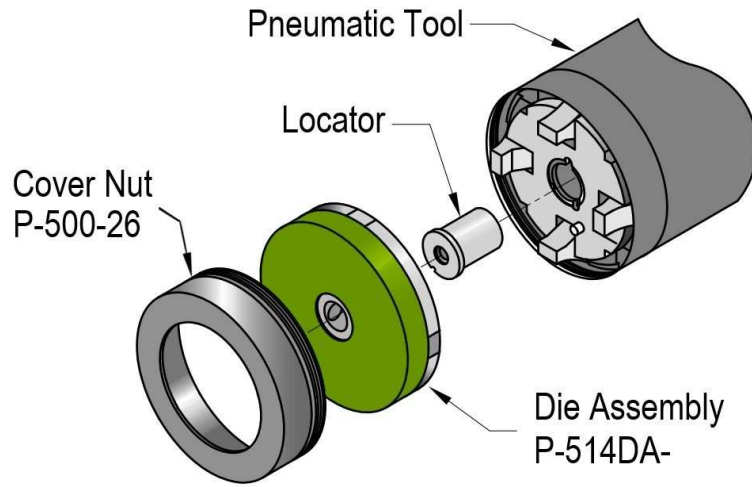

1. Insert the O-ring (P/N 6230-20) in the circular groove which is inside of the cover nut.
2. Do not over tighten the cover nut.
3. Turn the cover nut until you feel the O-ring make contact with the die assemblies face. At this point tighten it for an additional 15 – 20°.

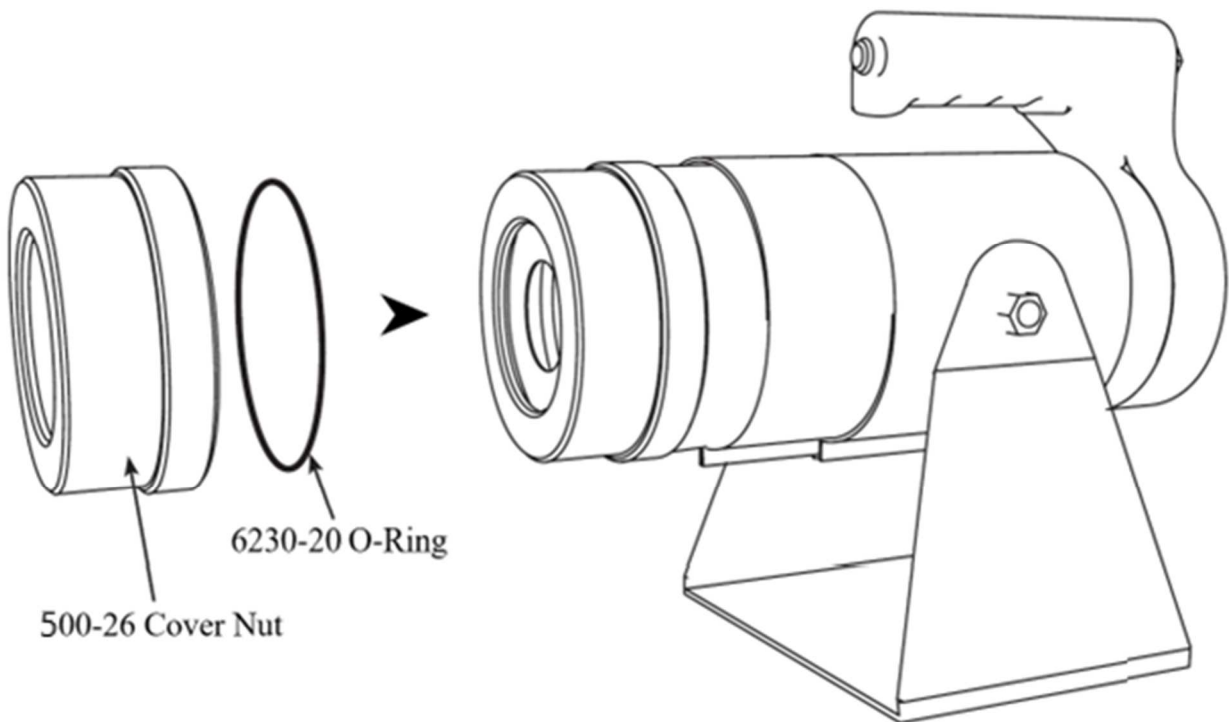



3. Calibration

Calibrating your tools on a regular basis is mandatory to maintain high quality crimp results. Please read the following steps (3.1 – 3.3) carefully.

3.1 Calibrating The Die Sets

All die sets are marked with their specific part number (**1**) and their nominal shut diameter (**2**). This is the diameter between the indentors when the die set is fully closed. The dies can be checked with Go No-Go gages. The tolerance is minus .005 in. (Go), plus .002 in. (No-Go).

Example: Die Assembly 514DA-16N has a nominal shut diameter of .048 in.
The Go dimension for this die is .043 in. (.048 minus .005 = .043 in)
The No-Go is .050 in. (.048 plus .002 = .050 in)

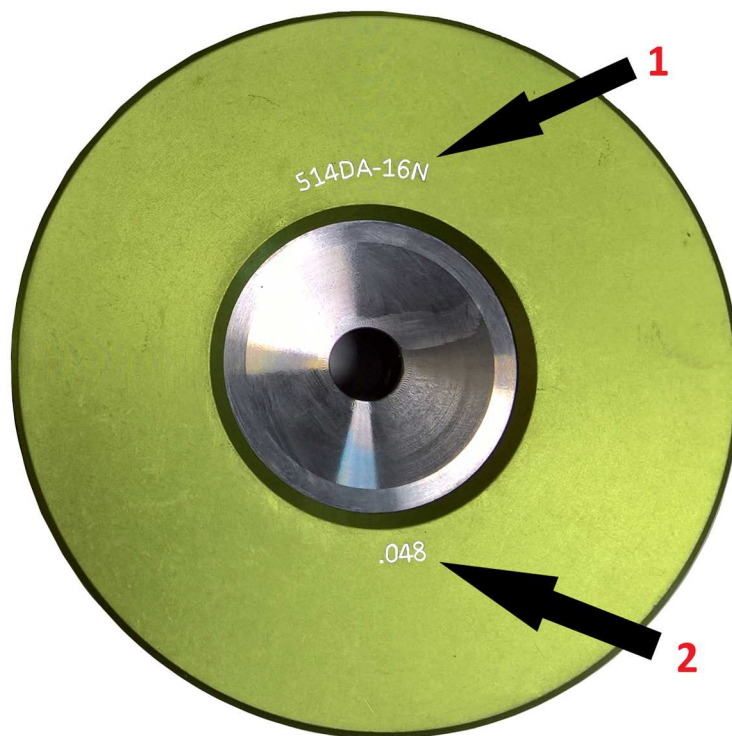



3.2 Changing The Indentors

It is possible to change the indentors in every die assembly. If your indentors are worn out, you can order a set of four indentors for your die assembly. Use the P/N 500-13- "your die set P/N" to order the new indentors.



The retaining ring (3100-375) is under pressure.

Be careful when assembling and disassembling, proper tooling is required.

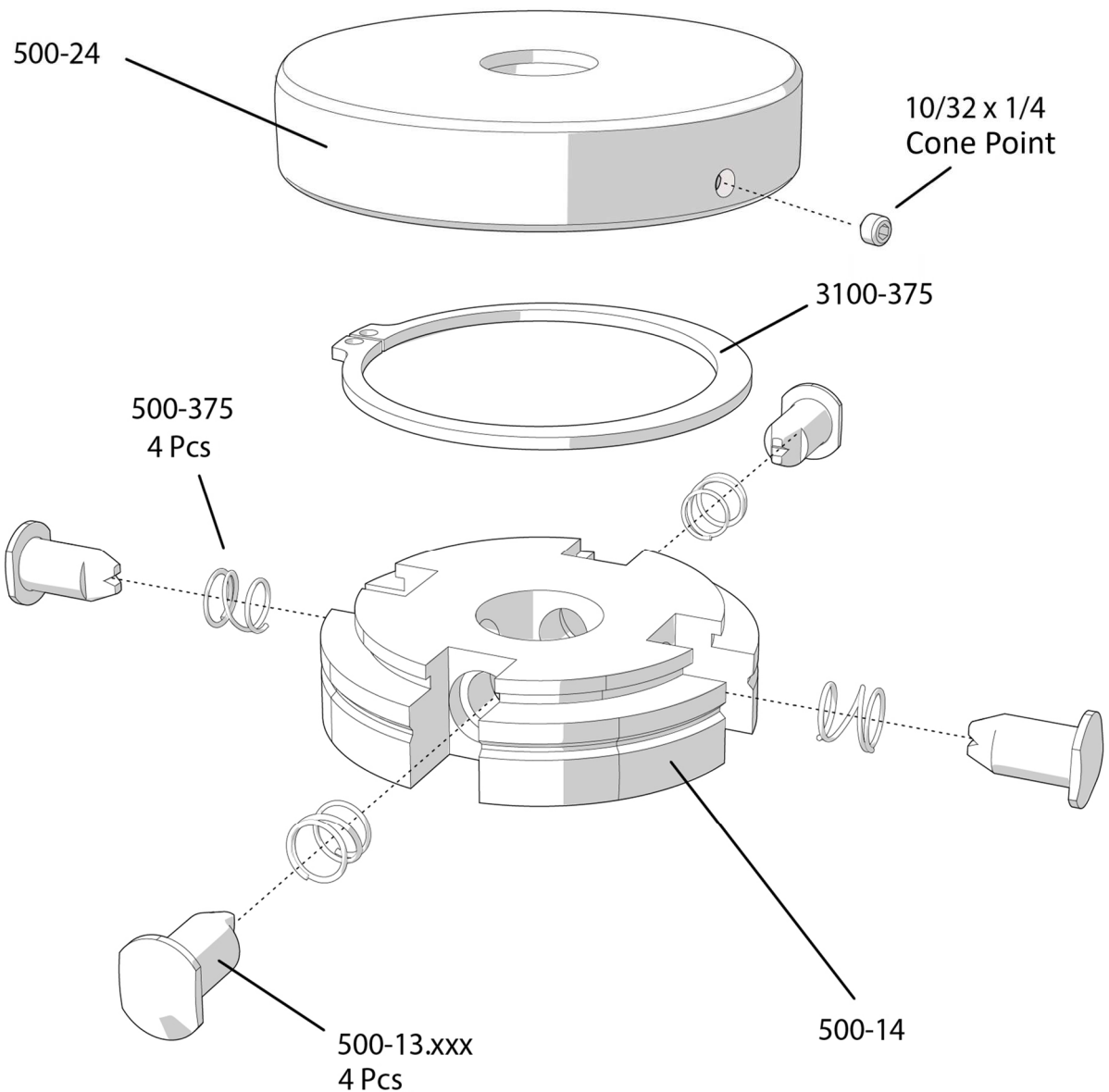



3.3 Perform Calibration

1. Select the proper Go No-Go gage for the die set which is installed.
2. Hand Trigger: Holding the trigger will cause the tool to remain in the closed position. The gage can then be used to check the opening between the indentors.
3. Foot Switch: If operating with a foot switch you will need to hold down the switch. The indentors will then remain closed for gaging.
4. EC-Unit: If operating with an EC-Unit you will need to hold down the gage button on the EC-Unit.





- The Go gage should enter freely. A snug fit is acceptable. If the Go gage does not enter freely into the die, check if you use the correct gage.
- The No-Go gage should not enter. If the No-Go gage enters the die, the indentors might be worn out. Less probable is that the arms are worn out.

**CAUTION**

Do not crimp against gage. This will damage the tool and void the warranty.

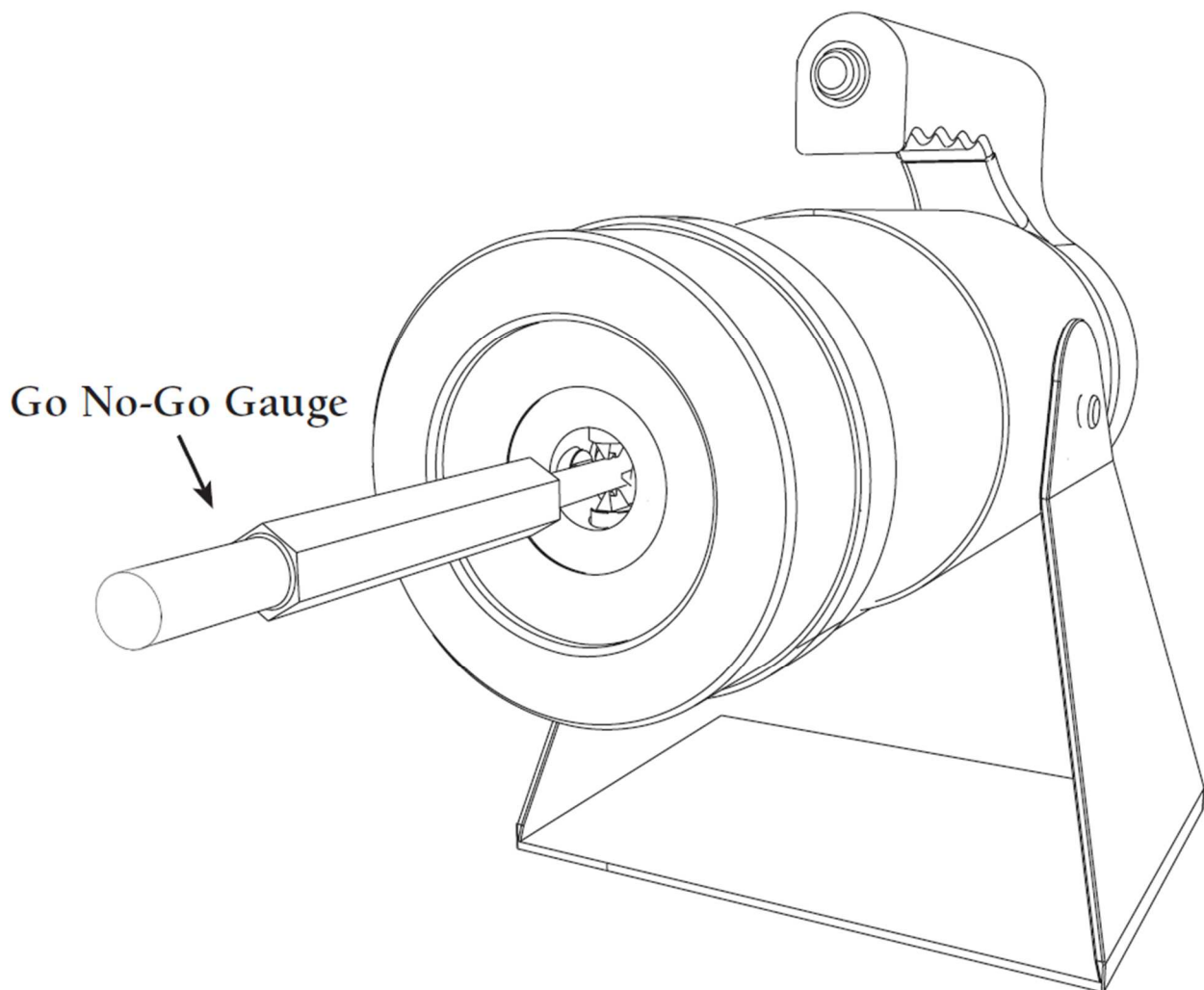



3.4 Calibrating The Tool

If a die set fails to calibrate, follow the steps below to calibrate the arms.

- Remove the cover nut and the die set.
- Operate the tool as described in 3.3 to hold the arms in position.
- Measure the distance between the faces of the two opposing arms (picture below).

This dimension should be 2.990 to 3.010 in. If this is not the case, the arms are out of alignment or worn out. Contact customer service for instructions.

i Ask a coworker for help if possible, so that you have both hands free for measuring.

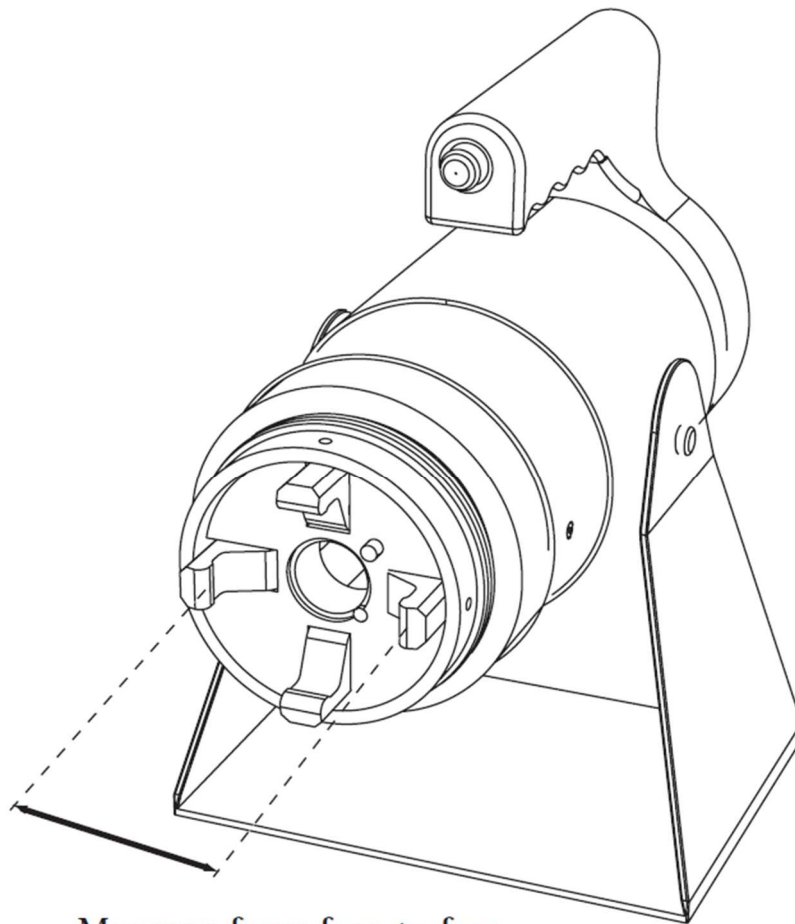

Measure from face to face



4. General Maintenance

The Rennsteig Pico Series tools should be supplied with filtered, dry air. The tools are thoroughly lubricated at the factory and if clean, filtered, dry air is provided, they should not require additional lubrication for the first year. The tools are assembled with the highest quality “O” ring lubrication and should provide adequate lubrication under normal conditions for the lifetime of the tool. If it becomes necessary to lubricate the tool, Dow Corning DC-55 O Ring lubricant is recommended.

Customer service is available to advise on additional repair questions which may occur. Additional information is available on request.

5. General Overhaul

General overhaul for the unit can be accomplished by disassembling the tool into its component parts, and after inspection, replacing parts as needed.



But please be aware that Rennsteig warranty does not apply to any products or part that has been subject to misuse, negligence, accident, vandalism, use outside of product design intent, or attempted repair/modification by anyone other than Rennsteig Tools, Inc.

Means: Disassembling the tool during the warranty period to repair any internal parts will void the warranty.

To solve problems, please contact customer service or send the tool to the factory for repair.



6. Exploded View P-500-D

Single Components

Part Number	#	Part Number	#	Part Number	#	Part Number	#
P-500-26	1	P-500-5	8	P-040W	15	P-500-30	22
P-6230-20	2	P-500-32	9	P-1/4-20 x 3/8	16	P-5/16-18 x 1-3/4	23
P-500-10T	3	P-6227-23	10	P-500-1	17	P-500-31	24
P-10-32 x 5/16	4	P-500-33	11	P-400-17	18	P-500-2C	25
P-500-18	5	P-500-2B	12	P-6227-28	19	P-6230-33	26
P-1/4-20 x 1/2	6	P-500-2A	13	P-6227-14	20	P-500-29	27
P-3000-550	7	P-568-353	14	P-500-1H	21		

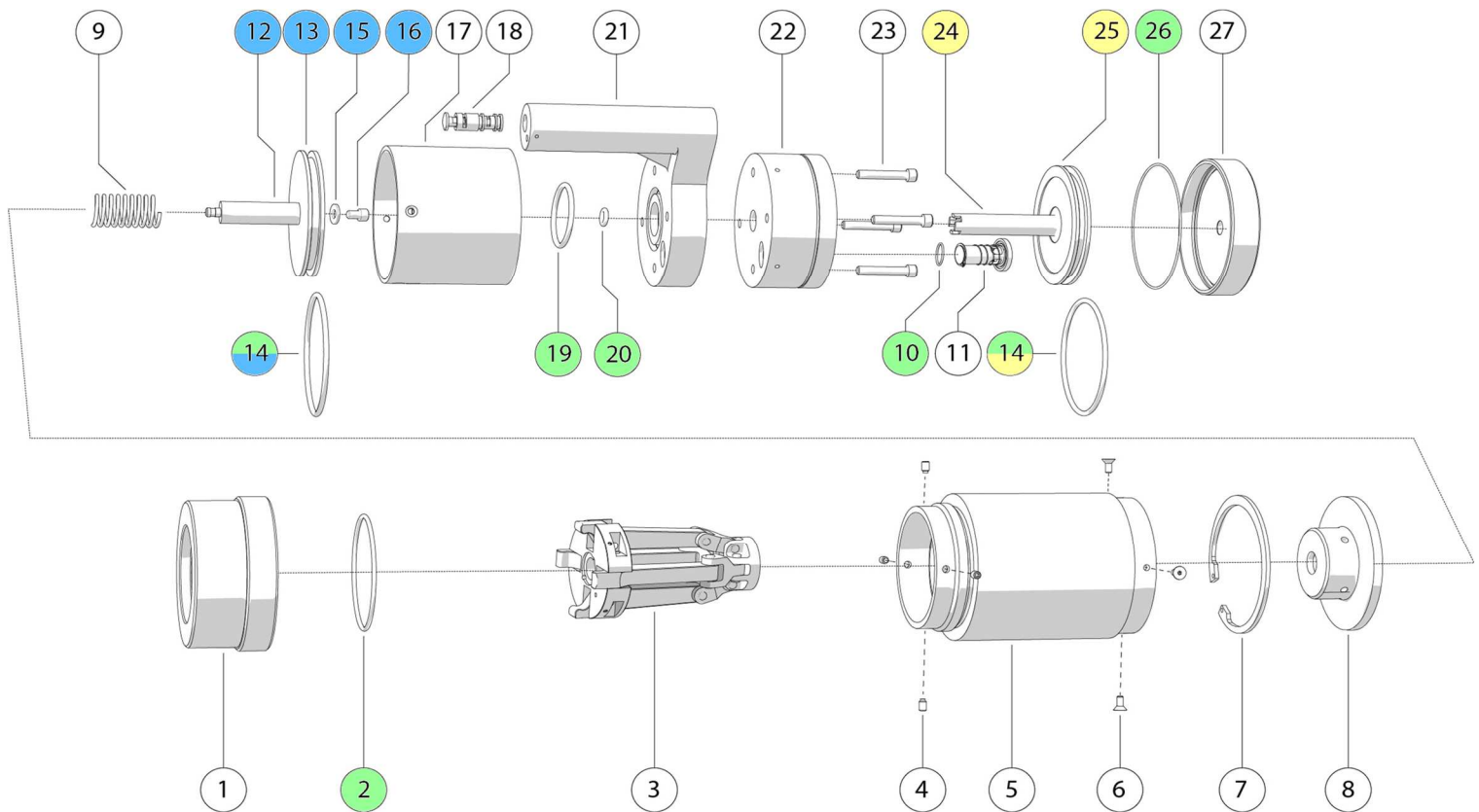

Sub-Assemblies

Kit Part Number	#	Kit Part Number	#	Kit Part Number	#	
O-Ring-Kit P-500-6200	2	Front Piston Assembly P-500-2A-2B	12	1st Booster	14	
	10		13		Piston Assembly P-500-2C-31	24
	14		14			25
	19		15			
	20		16			
	26					

Sales Office:
411 Hackensack Ave., Ste#200
Hackensack, NJ 07601
Email: sales@rennteig.us
Phone: 330-315-3044

Production Plant / Warehouse, CA
4040 Adolfo Rd.
Camarillo, CA 93012
Email: warehouse@rennteig.us

Warehouse, NJ
403 Kennedy Blvd.
Somerdale, NJ 08083
Email: info@rennteig.us

Principals:
Sascha Zmiskol
(President)
Mirko Reffke
(Vice President)
DUNS 941290558
Tax ID 20-423 3171



All colored components cannot be purchased individually. They are only available as content of kits as shown in the sub-assemblies.



7. Exploded View P-500-D-1

Single Components

Part Number	#	Part Number	#	Part Number	#	Part Number	#
P-500-26	1	P-500-5	8	P-040W	15	P-5/16-18 x 1-3/4	23
P-6230-20	2	P-500-32	9	P-1/4-20 x 3/8	16	P-500-31	24
P-500-10T	3	P-6227-23	10	P-500-1	17	P-500-2C	25
P-10-32 x 5/16	4	P-500-33	11	P-400-17	18	P-6230-33	26
P-500-18	5	P-500-2B	12	P-6227-28	19	P-500-29-1	27
P-1/4-20 x 1/2	6	P-500-2A	13	P-6227-14	20	P-5/16-18 x 5/8	28
P-3000-550	7	P-568-353	14	P-500-1H	21	P-500-31-1	29
				P-500-30	22	P-500-29	30

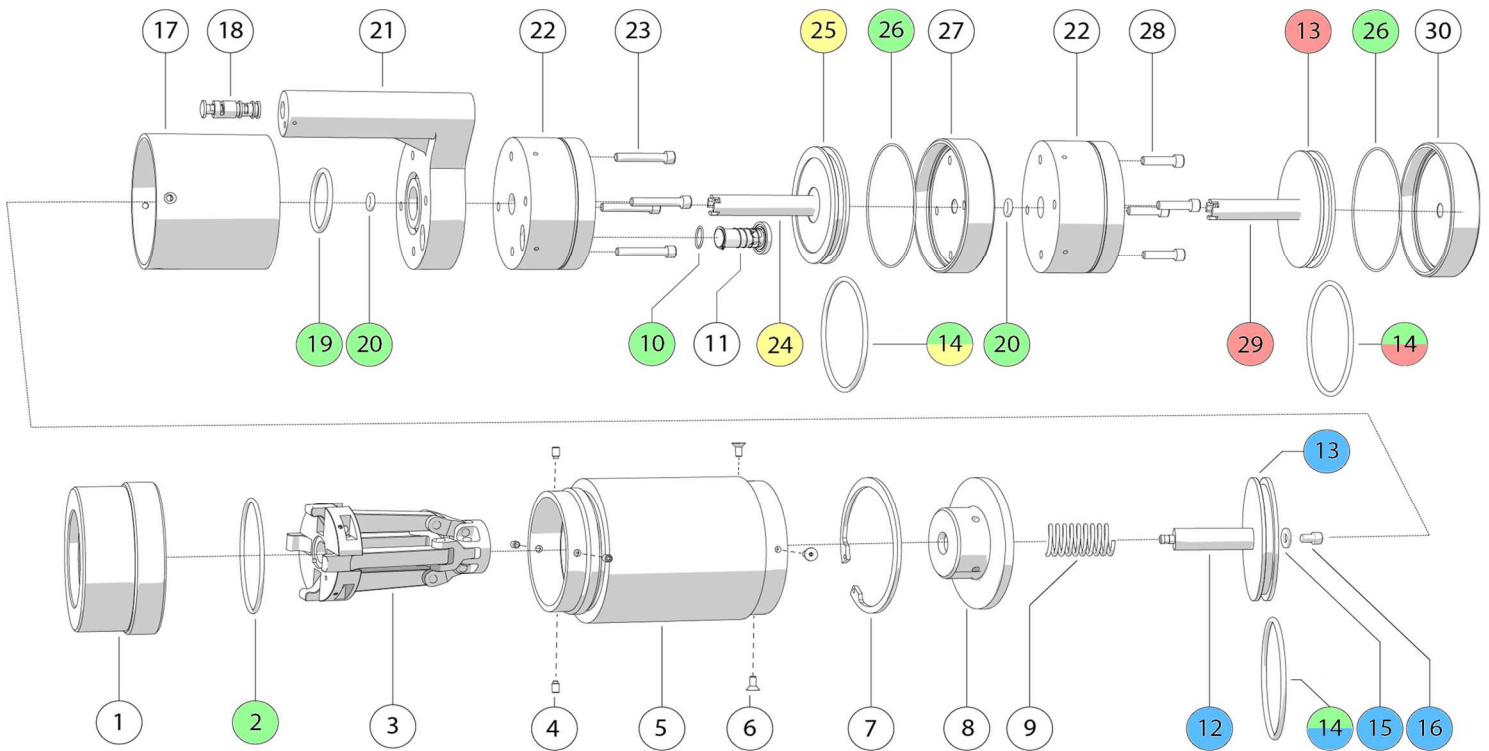

Sub-Assemblies

Kit Part Number	#	Kit Part Number	#	Kit Part Number	#	Kit Part Number	#
O-Ring-Kit P-500-6200	2	Front Piston Assembly P-500-2A-2B	12	1st Booster Piston Assembly P-500-2C-31	14	2nd Booster Piston Assembly P-500-2A-31-1	13
	10		13		24		14
	14		14		25		29
	19		15				
	20		16				
26							

Sales Office:
411 Hackensack Ave., Ste#200
Hackensack, NJ 07601
Email: sales@rennteig.us
Phone: 330-315-3044

Production Plant / Warehouse, CA
4040 Adolfo Rd.
Camarillo, CA 93012
Email: warehouse@rennteig.us

Warehouse, NJ
403 Kennedy Blvd.
Somerdale, NJ 08083
Email: info@rennteig.us

Principals:
Sascha Zmiskol
(President)
Mirko Reffke
(Vice President)
DUNS 941290558
Tax ID 20-423 3171



All colored components cannot be purchased individually. They are only available as content of kits as shown in the sub-assemblies.



8. Exploded View P-500-DEC

Single Components

Part Number	#	Part Number	#	Part Number	#	Part Number	#
P-500-26	1	P-500-5	8	P-500-1	15	P-500-31	22
P-6230-20	2	P-500-32	9	P-6227-28	16	P-6230-33	23
P-500-10T	3	P-500-2B	10	P-1187A2	17	P-500-29	24
P-10-32 x 5/16	4	P-500-2A	11	P-500-1H-EC	18	P-EC-8	25
P-500-18	5	P-568-353	12	P-6227-14	19		
P-1/4-20 x 1/2	6	P-040W	13	P-500-30	20		
P-3000-550	7	P-1/4-20 x 3/8	14	P-5/16-18 x 1-3/4	21		

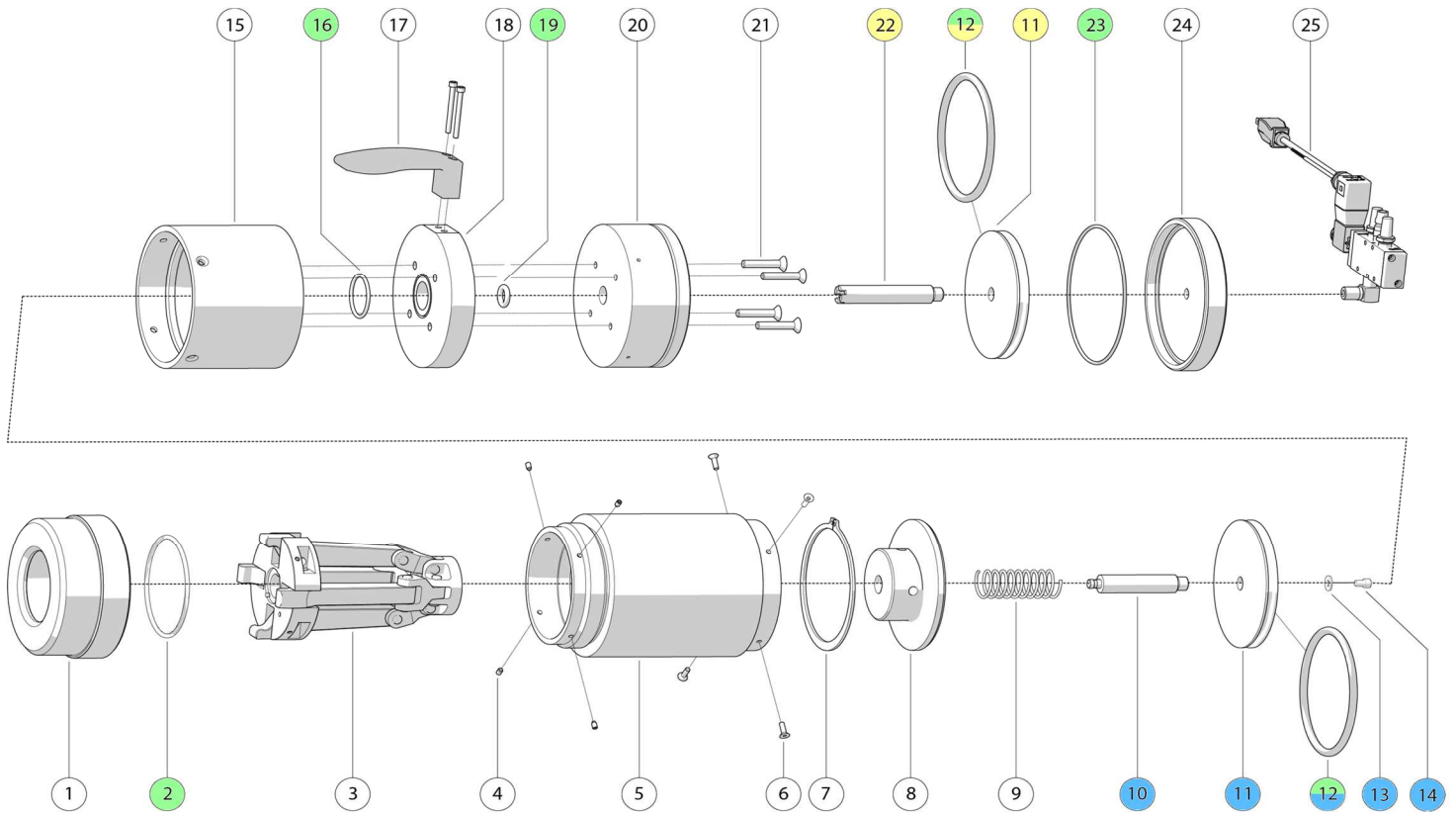

Sub-Assemblies

Kit Part Number	#	Kit Part Number	#	Kit Part Number	#
O-Ring-Kit P-500-6200	2	Front Piston Assembly P-500-2A-2B	10	1st Booster Piston Assembly P-500-2A-31	11
	12		11		12
	16		12		22
	19		13		
	23		14		

Sales Office:
411 Hackensack Ave., Ste#200
Hackensack, NJ 07601
Email: sales@rennsteig.us
Phone: 330-315-3044

Production Plant / Warehouse, CA
4040 Adolfo Rd.
Camarillo, CA 93012
Email: warehouse@rennsteig.us

Warehouse, NJ
403 Kennedy Blvd.
Somerdale, NJ 08083
Email: info@rennsteig.us

Principals:
Sascha Zmiskol
(President)
Mirko Reffke
(Vice President)
DUNS 941290558
Tax ID 20-423 3171



All colored components cannot be purchased individually. They are only available as content of kits as shown in the sub-assemblies.



9. Exploded View P-500-D-1EC

Single Components

Part Number	#	Part Number	#	Part Number	#	Part Number	#
P-500-26	1	P-500-5	8	P-500-1	15	P-500-31	22
P-6230-20	2	P-500-32	9	P-6227-28	16	P-6230-33	23
P-500-10T	3	P-500-2B	10	P-1187A2	17	P-500-29-1	24
P-10-32 x 5/16	4	P-500-2A	11	P-500-1H-EC	18	P-5/16-18 x 5/8	25
P-500-18	5	P-568-353	12	P-6227-14	19	P-500-31-1	26
P-1/4-20 x 1/2	6	P-040W	13	P-500-30	20	P-500-29	27
P-3000-550	7	P-1/4-20 x 3/8	14	P-5/16-18 x 1-3/4	21	P-EC-8	28

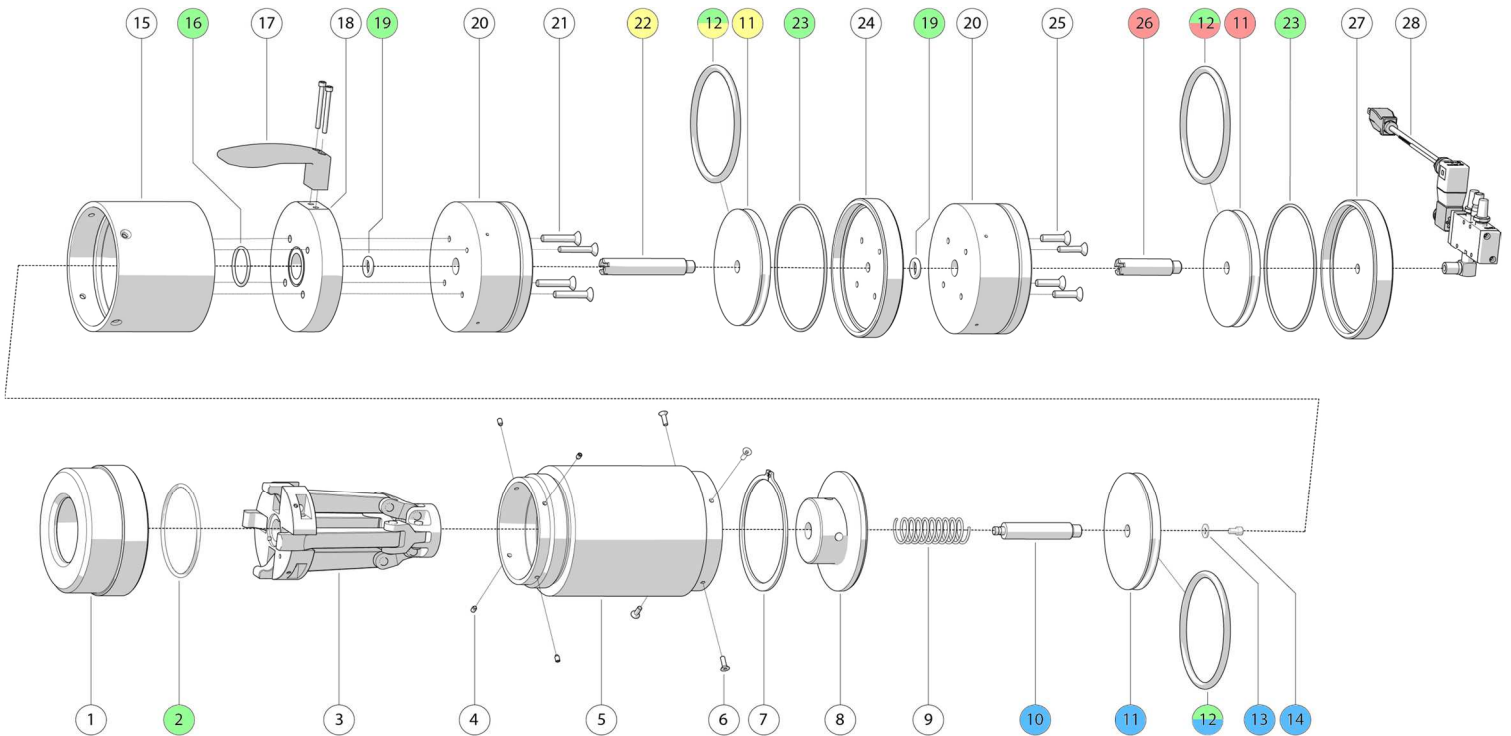

Sub-Assemblies

Kit Part Number	#	Kit Part Number	#	Kit Part Number	#	Kit Part Number	#
O-Ring-Kit P-500-6200	2	Front Piston Assembly P-500-2A-2B	10	1st Booster Piston Assembly P-500-2A-31	11	2nd Booster Piston Assembly P-500-2A-31-1	11
	12		11		12		
	16		12		12		
	19		13		26		
	23		14				

Sales Office:
411 Hackensack Ave., Ste#200
Hackensack, NJ 07601
Email: sales@rennsteig.us
Phone: 330-315-3044

Production Plant / Warehouse, CA
4040 Adolfo Rd.
Camarillo, CA 93012
Email: warehouse@rennsteig.us

Warehouse, NJ
403 Kennedy Blvd.
Somerdale, NJ 08083
Email: info@rennsteig.us

Principals:
Sascha Zmiskol
(President)
Mirko Reffke
(Vice President)
DUNS 941290558
Tax ID 20-423 3171



All colored components cannot be purchased individually. They are only available as content of kits as shown in the sub-assemblies.



10. Exploded View Toggle Assembly

Part Number	Minimum Order Quantity
P-500-9	4
P-500-10HD	4

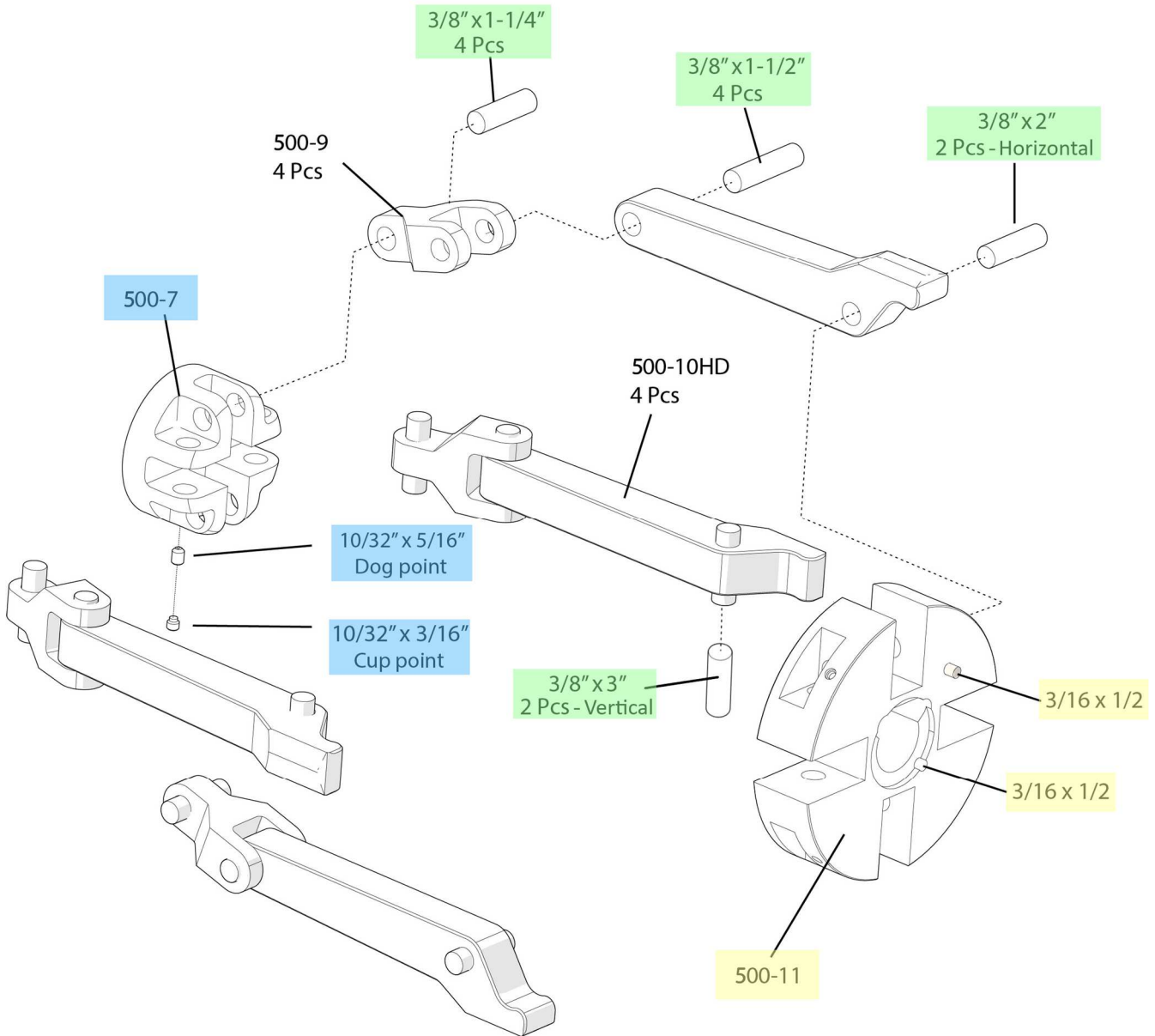

Kit Part Number	Item	Pieces	Kit Part Number	Item	Pieces	Kit Part Number	Item	Pieces
Dowel Pin Set 500-DPS	3/8" x 1-1/4"	4	Anchor 500-7	500-7	1	Retainer 500-11	500-11	1
	3/8" x 1-1/2"	4		10/32" x 5/16"	1		3/16" x 1/2"	2
	3/8" x 2"	2		10/32" x 3/16"	1			
	3/8" x 3"	2						

Sales Office:
411 Hackensack Ave., Ste#200
Hackensack, NJ 07601
Email: sales@rennteig.us
Phone: 330-315-3044

Production Plant / Warehouse, CA
4040 Adolfo Rd.
Camarillo, CA 93012
Email: warehouse@rennteig.us

Warehouse, NJ
403 Kennedy Blvd.
Somerdale, NJ 08083
Email: info@rennteig.us

Principals:
Sascha Zmiskol
(President)
Mirko Reffke
(Vice President)
DUNS 941290558
Tax ID 20-423 3171



All colored components cannot be purchased individually. They are only available as content of kits as shown in the sub-assemblies.



11. Cycling Valve Assembly

The Cycling Valve is enclosed by three other components (P/N: 500-1, 500-1H and 500-30).

11.1 Changing The Cycling Valve (P/N P-500-33)

Remove the retaining ring P/N P-4100-100 and pull the cycling valve out.



The retaining ring (4100-100) is under pressure.

Be careful when assembling and disassembling, proper tooling is required.

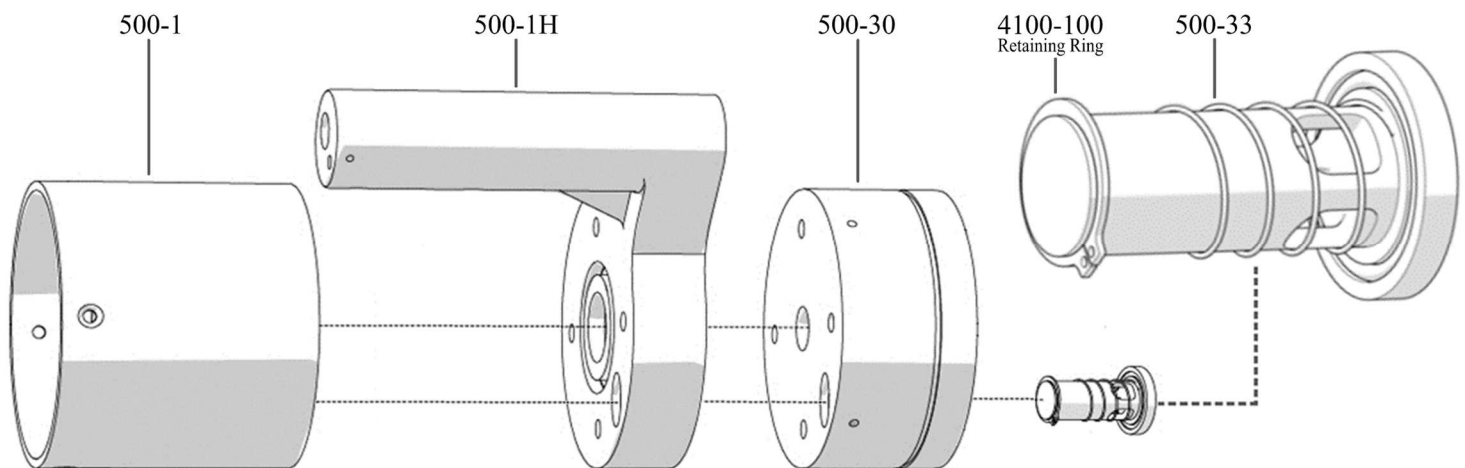



12. Customer Service

Call 1-805-388-5510 (PST – our operating hours Mon to Fri 9 AM to 4 PM)

When calling the customer service center regarding service, repair & maintenance to equipment a person familiar with the device should be present with a copy of the manual to receive instructions. Many difficulties can be avoided in this manner.

When calling or contacting us please provide the following information:

- Customer name
- Customer address
- Product part number (and serial number, if applicable)
- Urgency of request
- Nature of problem
- Description of inoperative components
- Video of error (visual evidence can often help us to understand and diagnose the malfunction more accurately)

At Rennsteig, we strive to make your purchasing experience as pleasant and easy as possible, and that includes making it easy for you to return a product to us. Please follow these simple procedures:

1. All returns must be factory authorized. Rennsteig Tools must issue a Return Material Authorization (RMA) prior to shipping. The RMA number can be obtained by mailing Customer Service: info@rennsteig.us . We will send you an email response with your RMA.
2. Please securely pack the product and write the RMA number on the outside of the shipping box, not the product box. **PRODUCTS RETURNED MUST BE RECEIVED BY Rennsteig Tools, Inc. IN RE-SALEABLE CONDITION. PRODUCT THAT CANNOT GO BACK TO STOCK AS RECEIVED WILL NOT BE ACCEPTED.**



13. Warranties And Claims

All Rennteig electrical, pneumatic and hydraulic driven tools are covered by a limited 180 day warranty. 90 days warranty applies for replaced components. Replacements and repairs provided under the warranty do not lengthen or renew the warranty period for the tool itself. The warranty period always commences when supplied; in case of doubt, proof of purchase documentation must be shown with verification of sale documentation, which must validate the purchase date and the product designation.

Within the guarantee period, the product warranty covers the rectification of all damage or faults affecting the tool, where such damage or faults are traceable to material or manufacturing defects.

Rennsteig Tools, Inc, will, under warranty obligation, repair or replace defective part/product at their discretion. Repair services include the cost of parts and labor.

Products may only be replaced for the same or comparable product(s) and with new products and after evaluation of the defective unit. In the event warranty does not apply, Rennteig Tools, Inc will supply an estimate of repair cost.

All returns must be factory authorized and Rennteig Tools, Inc, must issue a Return Material Authorization (RMA), prior to shipping. Returns will be shipped at the buyer's expense.

This warranty does not apply to any product or part that has been subject to misuse, negligence, accident, vandalism, use outside of product design intent, or attempted repair/modification by anyone other than Rennteig Tools, Inc. Rennteig Tools, Inc.'s sole liability for defects or breach of warranty shall be replacement of the parts involved, and, in no event, will Rennteig Tools, Inc. be liable for special or consequential damages or losses including property damage or other loss as related directly or indirectly to the use of Rennteig Tools, Inc's products. In no event is Rennteig Tools, Inc. liable for consequential damage caused by installation or damage caused by acts of nature.

Rennsteig Tools, Inc. claims no liability for the cost of installation, or any other cost incurred during the use of products manufactured by Rennteig Tools, Inc. No warranty is made or implied as to the merchantability of any products or for the suitability or fitness of such products for the Customer's intended use. No representative is authorized to assume additional liability for Rennteig Tools, Inc. In no case will Rennteig Tools, Inc, be liable for any cost incurred in removing or installing the product, even if the product had failed under a covered Warranty.

If damage occurs from a customer coordinated shipment(s), Rennteig Tools, Inc is not responsible for repair or replacement.

Products that are non-operational out of the box are considered to be DOA and are subject to the following procedure. The DOA period is the first seven days of receipt by customer of the product. DOA products will be replaced but must be accompanied by an RMA number from Rennteig Tools, Inc. If the product fails after seven days, the Warranty Policy will go into effect.

Damage due to shipping the products to the customer is covered under the freight carrier's insurance. Rennteig Tools, Inc carriers have the right to assess damage claims and either accept or deny a claim. Rennteig Tools, Inc has no control over damage claims and cannot guarantee a claim award or product replacement. If the freight carrier does not accept a damage claim, Rennteig Tools, Inc reserves the right not to replace the product.

All prices quoted by Seller are subject to adjustment due to Purchaser's change orders, if any, that are subsequently accepted by Seller.

The list price quoted for a Product excludes the cost of packaging, the cost of special containers, packaging, crating, palletizing, applicable taxes and duties, shipping, insurance, or other incidental expenditures of Seller, all of which additional charges the Purchaser shall be responsible for.



14. Notes

.....

.....

.....

.....

.....

.....

.....

.....

.....

.....

.....

.....

.....

.....

.....

.....

.....

.....

.....

.....

.....

.....

.....

© 2023 Rennsteig Tools, Inc. All Rights Reserved.

Rennsteig Tools and Rennsteig Tools (logo) are trademarks.
Logos, products, or images may be trademarks of Rennsteig Tools, Inc. or other respective owners.

No part of this document may be reproduced, copied, transmitted stored in a retrieval system, or translated into any language in any form by any means without the written permission of Rennsteig Tools, Inc.

Any rights not expressly granted herein are reserved.



15. Also Available from Rennteig

Cutting Tools



Pneumatic Powered Tools



Stripping Tools



Crimping Tools



Tools for Solar



Sales Office:
411 Hackensack Ave., Ste#200
Hackensack, NJ 07601
Email: sales@rennteig.us
Phone: 330-315-3044

Production Plant / Warehouse, CA
4040 Adolfo Rd.
Camarillo, CA 93012
Email: warehouse@rennteig.us

Warehouse, NJ
403 Kennedy Blvd.
Somerdale, NJ 08083
Email: info@rennteig.us

Principals:
Sascha Zmiskol
(President)
Mirko Reffke
(Vice President)
DUNS 941290558
Tax ID 20-423 3171